

# AuthenTec EntréPad 4000

Secure Mid-Size Touch Sensor for the PC Market



The EntréPad 4000 is AuthenTec's mid-size, advanced security touch sensor for the PC market.

Used in a variety of notebooks and PC peripherals throughout the world, the **EntréPad 4000** has imaging superior to larger optical or DC capacitive sensors. And with its integrated Universal Serial Bus and wide pixel array, the sensor can be used with AuthenTec's TrueMatch or other third-party fingerprint matchers.

The **EntréPad 4000** includes AuthenTec's unique Power of Touch, enabling manufacturers to easily and cost-effectively add new security, convenience, and personalization functions that are controlled by the simple touch of your finger. With the Power of Touch, the same sensor allows manufacturers to add features that differentiate the PC and improve the user experience.

## KEY FEATURES AND BENEFITS

### SUPERIOR TECHNOLOGY

- TruePrint technology provides the most accurate fingerprint image
- TrueMatch pattern matching technology runs on high-performing host processor

### TRUSTED SECURITY

- Digitally signed images
- Challenge response protocol between sensor and software
- 256-bit AES encrypted fingerprint templates

### USER UPGRADEABLE

- Secure HDD storage and matching algorithms and template – not ROM
- Users can easily upgrade matcher to latest version
- Protects users from future sensor attacks

### EASY TO USE

- Able to read virtually every fingerprint
- Pattern matching technology delivers the industry's best enroll, verify and reject performance (false accept/false reject)
- Ultra hard surface coating withstands greater than 1 million touches

### ROBUST APPLICATION SOFTWARE FEATURE SET

- Supports multi-factor authentication -- combining the sensor with smartcards, TPM, etc
- Login and password replacement
- File/folder encryption, secure email, password replacement, and secure file sharing

### THE POWER OF TOUCH

- Enables unique touch powered features
- Quick application launch, fast user switching, and more

### LOW SOLUTION COST

- Highly integrated sensors
- Minimal bill of materials

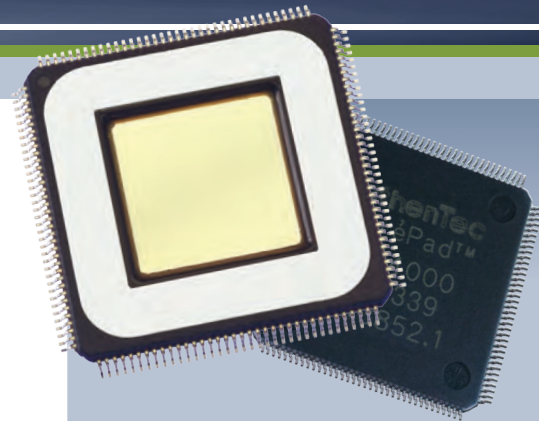

LAPTOPS



DESKTOPS



MICE



PC CARDS

The Power of Touch

# AuthenTec EntréPad 4000

## THE AUTHENTEC DIFFERENCE

### SUPERIOR TRUEPRINT AND TRUEMATCH TECHNOLOGIES

The EntréPad 4000 employs AuthenTec's award winning TruePrint® and TrueMatch technologies, the most accurate sensor and pattern matching technologies in the industry. These combined technologies capture the highest quality fingerprint images – resulting in significantly better performance than any other solution on the market today.

### THE POWER OF TOUCH

AuthenTec's unique Power of Touch approach combines the most advanced security, with additional convenience, navigation and personalization functions controlled by the simple swipe of your finger. The Power of Touch enables PC manufacturers to easily and cost-effectively add capabilities such as data protection, password replacement, finger-control scrolling, quick applications access, fast user switching and other functions.

## EntréPad 4000 SPECIFICATIONS

High Performance Features	Advanced security Integrated USB interface
Form Factor	144-pin LQFP package 20mm x 20mm x 1.4mm
Robust Packaging	Scratch and impact resistant Ultra hard surface coating withstands greater than 1 million touches RoHS compliant / Lead Free
Detection Matrix	96 x 96 pixels @ 250 ppi 9.75mm x 9.75mm
SelectaBus	Asynchronous serial interface 8-bit parallel interface Universal Serial Bus
Operating Voltage Range	3.3V or 5.0V
Commercial Temperature Range	-20C to +70C
Current Consumption @ 3.3V	65mA imaging 5mA finger detect
ESD Resistance	IEC 61000-4-2 Level 4 (+/- 15KV)
Supported Operating Systems	Microsoft Windows Vista and XP

## EntréPad 4000 INTEGRATED FINGERPRINT MODULE

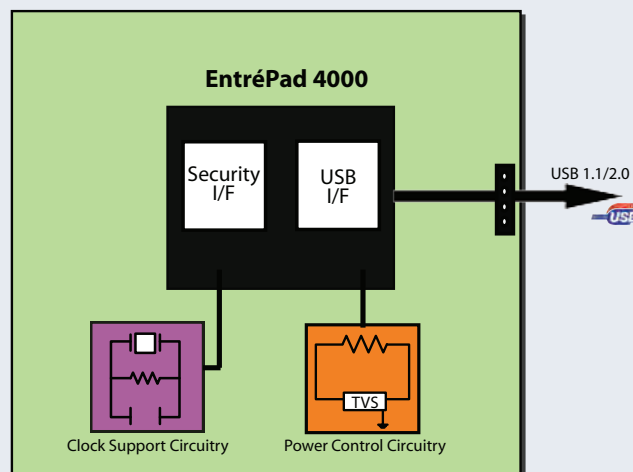

## THE AUTHENTEC TOTAL SOLUTION

AuthenTec offers the most complete and flexible solution to enable manufacturers to design in advanced biometric fingerprint sensors. Our total solution approach includes a complete family of sensors; hardware and software kits for easy evaluation and integration; proven solutions from more than 50 hardware, software and design partners; and end-to-end integration support from an experienced technical staff.

## CONTACT US

### NORTH AMERICA

AuthenTec | U.S. Headquarters  
709 South Harbor City Blvd.  
Melbourne, FL 32901 USA  
phone: 321-308-1300

### San Jose, CA

phone: 408-879-2383

### EUROPE

Germany | Munich  
phone: 49 (8444) 918290

### ASIA

China | Asia Headquarters  
4000 Wen Xiang Road  
Songjiang Shanghai 201616  
phone: 86-21-5776-3300

### Japan | Tokyo

phone: 81-80-5026-9710

### Taiwan | Taipei

phone: 886-2-8758 2719

### Korea | Seoul

phone: 82-11-380-6164

**WORLDWIDE REPRESENTATIVES NETWORK**  
A complete listing of AuthenTec's network of representatives is available at our web site.

[www.authentec.com](http://www.authentec.com)

